

Cain Industries Savings Analysis Study





CG260-16 Engine Heat Recovery Steam Generator
Re-Circulation Design with Exhaust Gas Bypass

Ref: 60938
Rep: 24290201
Rev: 0 **DRAFT**

Date: 3/13/2018
Page: 1

Engineered For:

ABC Company
P.O. Box 333
Mayville, WI 55555

Attn: Joe Foster
Ph: (555) 555-5555
Fax: (555) 555-1234

End User:

XYZ Company
PO Box 300
3333 W. Deer Blvd
Bloomville, WI 33333

Attn: Dave Calley
Ph: (333) 333-3333
Fax: (333) 333-1234

Exhaust Heat Recovery Proposal:

Cain Industries is pleased to propose the following ESG1 model exhaust steam generator to recover exhaust heat from a natural gas fired engine and produce 10 psig steam.

The ESG1 is packaged and skid mounted, forced circulation, water tube, heat recovery steam generator. It has an automatic, modulating, exhaust gas bypass controlled by steam pressure. The ESG1 contains a bypass section, heat exchanger section and steam flash drum assembly. Steam is produced in 5-10 minutes from a cold start-up.

In the event of loss of power, the bypass will fail in the bypass (open) position. In the event of an alarm condition, i.e., high water, low water, excess steam pressure, the bypass will be driven to the bypass position.

The heat exchanger section and the steam flash tank are insulated. The exhaust gas bypass will have 4" thickness blanket wrap insulation. The interconnecting piping is not insulated and field insulating is recommended.

The exhaust gas bypass is stainless steel with stainless steel flanges.

The steam pressure controller will have Modbus communications for re-transmission of the process variable and remote set point capability. The water level controller will also have Modbus communications for re-transmission of the process variable. Contacts will be provided to remotely drive the exhaust gas bypass to the bypass position. The panel is UL approved

The ESG1 must be indoors, or in a heated enclosure, protected from the elements, from freezing, and from excessive heat.

The annual operating hours and the cost per therm (100,000 Btu) of natural gas were assumed.

"Manufacturing Waste Heat Transfer Products To Save Energy"

Boiler Economizer Systems · Gas & Diesel Cogeneration Systems · Fume Incineration Systems
Exhaust Steam Generators · Finned Tubing



CG260-16 Engine Heat Recovery Steam Generator
Re-Circulation Design with Exhaust Gas Bypass

Ref: 60938
Rep: 24290201
Rev: 0 **DRAFT**

Date: 3/13/2018
Page: 2

Waste Heat Exhaust:

Primary Fuel Type: Natural Gas
Secondary Fuel Type:
Fuel Cost per 100,000 BTU (USD): \$0.65

Heat Source: Cat CG260-16 engine
Exhaust Flow: Horizontal/Vertical
Heat Sink: Steam

Model: ESG1-A30L15CSS

Overall Length, inches	149	Customer Connections:	
Overall Width, inches	97	Exhaust Connections	30" Dia.
Overall Height, inches	135	Steam, RF Flange	8
Dry Weight, lbs.	21000	Boiler Feedwater, NPT	3/4
Wet Weight (10.4 ft ³), lbs.	21650	Blowdown Manifold	1
Surface Area, Ft ²	5,718	Steam Safety Valve, NPT	2
Design Pressure, PSIG	15	Control Air, NPT	N/A
Operating Steam Pressure, PSIG	10	Circulator Motor HP	10
Hydrostatic Test Pressure, PSIG	23	Voltage	230/460
@ Design Temperature, °F	550	Phase 3	Hertz
Maximum Entering Temperature, °F	1000		60

Performance:

	Load 1
Load of Maximum Output, %	100%
Exhaust Entering Temp, °F	837°
Exhaust Flow Rate, SCFM	10462
Exhaust Leaving Temp, °F	302°
Pressure Drop " W.C. Max	1.43
*Equivalent Evaporation, lb/hr	7029
Boiler Horsepower, BHP	204
Boiler Feedwater Flow, GPM	14.6
Heat Recovered, MBTU/Hr	6820
(*From and at 212°F)	

Savings:

Heat Saved (x 100 MBTU/Hr)	68.202
Annual Hours of Operation	8000
ANNUAL SAVINGS (USD)	\$354,651

"Manufacturing Waste Heat Transfer Products To Save Energy"

Boiler Economizer Systems · Gas & Diesel Cogeneration Systems · Fume Incineration Systems
Exhaust Steam Generators · Finned Tubing



CG260-16 Engine Heat Recovery Steam Generator
Re-Circulation Design with Exhaust Gas Bypass

Ref: 60938
Rep: 24290201
Rev: 0 **DRAFT**

Date: 3/13/2018
Page: 3

Quotation:

Qty	Part #	U/M	Description
1		EACH	ESG1-A30L15CSS -INCLUDING: Skid Mounted Packaged Design Full Modulating Exhaust Bypass Full Boiler Control Trim Factory Insulation Water Level Control Low Exhaust Friction Loss 10 Ga. Steel Exterior Stainless Steel Inner Lining ASME & Nat'l Board Stamped
	915015		304 SS Exhaust Gas Bypass
	914011		2-13 PSIG O.P. (Design:15)
	940060		Alarm Dry Contacts
	964030		4" Thks. Factory Insulation
1	964791	EACH	Bypass Insulation ESG1-AXXL 4"T
	425160		Automatic surface blowdown

TOTAL PRICE (USD) \$201,007

ANNUAL RETURN ON INVESTMENT 176%
5 YEAR SAVINGS \$1,773,255
10 YEAR SAVINGS \$3,546,510
PAYBACK PERIOD, MONTHS 6.8

Terms of Sale:

- * Estimated Shipping: 12-14 weeks after submittal approval
- * Payment Terms: See "Terms of Sale" Bul. #25500
- * See Bulletin 25500 including 'Warranty and Performance Guarantee'.

Representative

9:17::n

Reference Application

DATE: 3/13/2018

REF#: 60938

FOR: ABC Company

REV#: 0 **DRAFT**

c/o: Reference Application

MODEL: ESG1-A30L15CSS

HEAT SOURCE: Cat CG260-16 engine

Bul.# 10950

PARTS LIST

(SEE DESIGN DATA FOR CONSTRUCTION)

1. LIFTING EYE
2. STEAM PRESSURE CONTROLLER
3. MODULATING FEEDWATER VALVE
4. ASME STEAM SAFETY VALVE
5. STEAM OUTLET FLANGE (STEAM STOP & CHECK VALVE SUPPLIED BY OTHERS)
6. STEAM FLASH DRUM/DRY PIPES (INSULATED)
7. EXCESS STEAM PRESSURE SWITCH
8. WATER LEVEL CONTROL W/LOW & HIGH WATER CUTOUT & MANUAL RESET LOW LOW WATER
9. LOCALIZED PIPING CONNECTIONS: FEEDWATER, BLOWDOWN MANIFOLD, 100 PSIG CONTROL AIR (WHEN REQ'D FOR PNEUMATIC DAMPER ACTUATOR)
10. TUBE REMOVAL ACCESS DOOR
11. STRUCTURAL STEEL BASE
12. MODULATING EXHAUST BYPASS

ESG1

PERFORMANCE
AND
DIMENSION DATA

A.	837 °F
B.	302 °F 10 PSI 204 BHP
C.	149x97 "
D.	135 "
E.	8 " CONN.
F.	30" Dia. " CONN. 21000 # WGT 5,718 H.S. 15 PSIG 1000 TEMP.

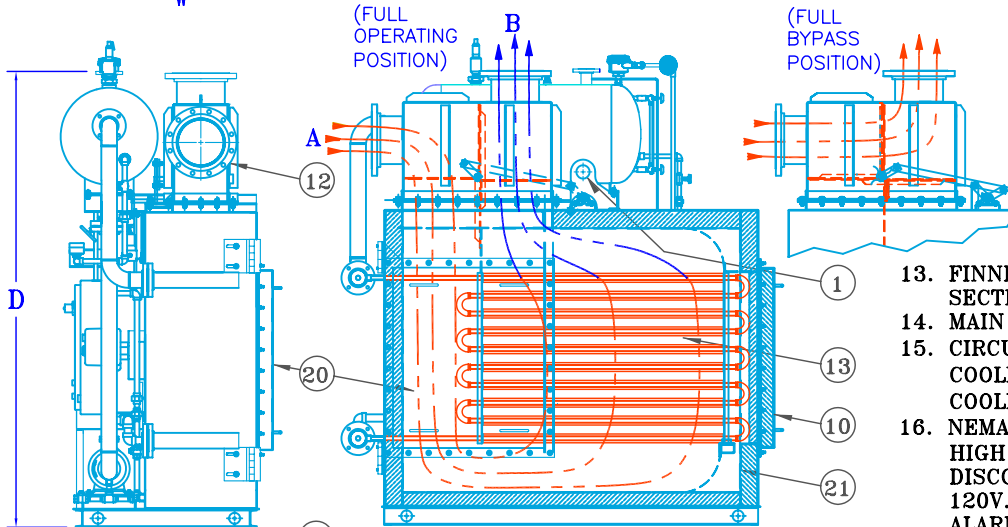
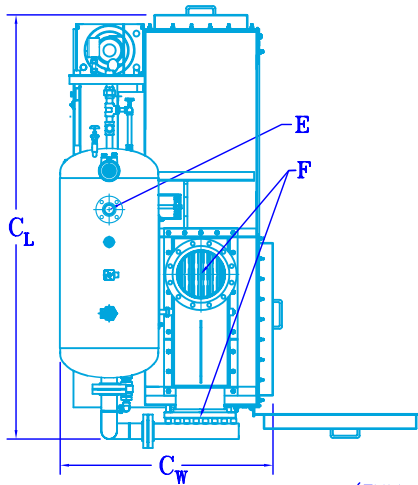

13. FINNED TUBE HEAT TRANSFER SECTION
14. MAIN BLOW DOWN VALVE ASSY.
15. CIRCULATING PUMP ASSY W/SELF COOLING CIRCULATING PUMP (NO COOLING WATER REQUIRED)
16. NEMA 12 CONTROL PANEL: (SINGLE HIGH VOLTAGE CONN.) FUSE DISCONNECT MAGNETIC STARTER, 120V. STEPDOWN TRANSFORMER, ALARM LIGHTS
17. 10GA. SHELL (3" THKS. INSULATED)
18. CONTINUOUS SURFACE BLOWDOWN
19. MODULATING ACTUATOR W/FAILSAFE TO BYPASS
20. MAIN INSPECTION DOOR, HINGED
21. STAINLESS STEEL INTERIOR

NOTES:

- A. OPTIONAL INSULATION AS REQ'D:
 -SHELL THICKNESS INSULATION:
 4" 6" 8" 12"
 -BYPASS JACKET INSULATION:
 2" 3" 4" 6" 8"
 (EXTERNAL PIPING INSULATION INSULATED BY OTHERS AS REQ'D)
- B. EXHAUST FLANGE CONN.S:
 2x2 ANGLE RING (STANDARD)
 150LB ANSI HOLE PTN (OPTIONAL)
- C. A.S.M.E. & NAT'L BOARD STAMPED - SEC.I, DIV.I

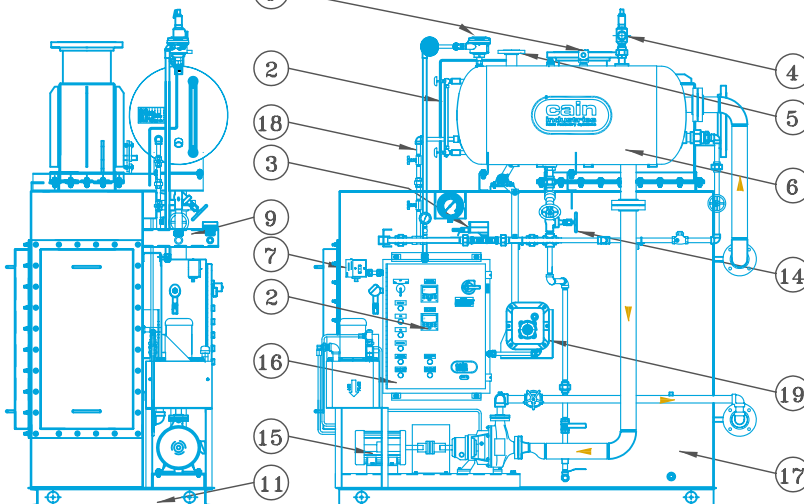

WASTE HEAT RECOVERY SAVINGS CERTIFICATE

For:
XYZ Company

Operating a Cain Industries Model:
ESG1-A30L15CSS

Recovering BTU from the Exhaust of:
Cat CG260-16 engine

Savings Analysis Review Prepared on 3/13/2018:

Thank you for considering the Cain Industries fuel savings proposal. This Savings Certificate highlights the savings and payback that your company can anticipate based on your current fuel expense, combustion operating conditions submitted to Cain Industries and/or assumptions as noted.

Savings:

\$44.33 / Hour
\$1,137 / Day (Assume 6 days per week operation)
\$6,820 / Week
\$29,554 / Month
\$354,651 / Year (R.O.I.: 176%)
\$1,773,255 / 5 Years
\$3,546,510 / 10 Years

Life Expectancy: **\$7,093,020** (20 Years)

Out Right Purchase:

Based on the total Cain equipment cost, this equates to a Monthly Payback of **\$29,554** -or- the equivalent of an annual "Return on Investment" of **176%** (based on present fuel costs). Your payback clock will begin as soon as the Cain exhaust recovery model is installed and placed into operation.

If you were to borrow money to pay for the Heat Recovery System:

Based on your input data, your anticipated Monthly Fuel Savings of **\$29,554** and the Payback Period of **6.8 months**, can be considered to fund the monthly payments in an optional lease/purchase plan.

Following the Payback Period, your annual return on investment from a Cain Industries Heat Recovery System will be **176%** each year for the next **19.4** years for a Grand Total of **\$6,892,013** over the life expectancy of the equipment!

Your current fuel savings status:

Lost savings from the original quote date of 2/15/17 - 3/13/18 presently is **\$380,895** as calculated from your Cain Savings Analysis Study Ref. 60938.

Your Bottom Line:

- Expect guaranteed performance!
- Realize you have a no risk investment!
- Annual return on investment of 176% for the next 20 years!
- A Lease vs. Budget offers the most immediate exhaust heat recovery start date!
- As fuel costs begin to rise again so will your Monthly Fuel Savings!

Ref: 60938 Rep: 24290201 Rev: 0



Environmental Impact Assessment

YOUR ANNUAL POLLUTION ELIMINATION

What if you could prevent pollution while saving your company money? Cain Industries exhaust heat exchangers transform industrial combustion and cogeneration (CHP) operations into more fuel efficient systems. Guaranteed heat recovery performance delivers fuel consumption reduction and the elimination of related pollution. It's a simple fact... Burn less fossil fuel, produce less pollution! Industrial exhaust heat recovery is the only choice for the health of the planet and a healthy bottom line.

Cain Industries model ESG1-A30L15CSS eliminates 54.7 million cubic feet of CO₂ emissions each year equivalent to:



Cars NOT Driven

Your **annual pollution offset** is equivalent to 620 cars parked, or 7,097,080 miles never driven. The EPA reports that the average passenger vehicle travels 11,443 miles per year, emitting 4.67 metric tons of CO₂ and equivalent gases.



Acres of U.S. Forest Carbon Absorption

Your **annual pollution offset** is equivalent to the carbon sequestered by 3,407 acres of U.S. forest, or 132,994 mature trees. Growing trees absorb carbon dioxide from the atmosphere through photosynthesis and store it as carbon in the form of wood. The EPA reports that 0.85 metric tons of CO₂ are sequestered annually by one acre of average U.S. forest. A mature tree absorbs carbon dioxide at a rate of 48 pounds per year.



CO₂ Metric Tons Eliminated

Your **annual pollution offset** is equivalent to eliminating 2,896 metric tons, or 6,383,717 pounds of CO₂ from the environment by reducing fossil fuel consumption. Natural gas and fuel oils release carbon dioxide as the principal product of combustion. Carbon monoxide is released when fuel is not completely burned. Oil combustion produces sulfur dioxide that interacts with other gases and particles in the air to form harmful sulfates.



Raw Exhaust Prevention

Your **annual pollution offset** is equivalent to preventing a 471 foot diameter volumetric sphere of raw combustion exhaust from being released into the atmosphere, consisting of carbon dioxide (CO₂), carbon monoxide (CO), sulfur (SO₂), nitrogen dioxide (NO_x), nitrogen oxide (N₂O), volatile organic compounds (VOCs) or hydrocarbons (HCs), depending on your fuel type.

Results are based on your combustion exhaust output, EPA and EIA data.

Ref: 60938 Rep: 24290201 Rev: 0





Lease Your Fuel Savings **NOW!**

Cain Industries now provides a competitive fixed rate lease option for all exhaust heat recovery systems sold in the US. Lease payments are lower than the equipment's monthly fuel savings, based on our guaranteed equipment performance. Money once spent on monthly fuel bills now funds the lease payment. A lease expedites equipment acquisition and installation by transforming capital budget constraints into a simple monthly operating expense. The lease typically represents 4-7% of the fuel savings achieved by our equipment over a 20-year life expectancy. Lease Cain Industries equipment and installation or finance an entire boiler room or cogeneration project! Contact Cain Industries today for more information.

- Lease Cain Industries equipment and installation... Or finance an entire turnkey project.
- Lease payments are always lower than the monthly fuel savings from Cain equipment.
- Lease offers a competitive fixed rate with flexible terms.
- Leasing expedites equipment acquisition, installation and fuel savings.
- Lease requires no down payment and provides 100% financing.
- Lease equipment now instead of facing a capital budget delay.
- Capital budget constraints are transformed into a simple monthly operating expense.
- 8 out of 10 companies use a lease to purchase equipment.
- Easy 1 page application with quick credit decision turnaround.



Cain Industries
PO Box 189
W194 N11826 McCormick Drive
Germantown, WI 53022 USA
262-251-0051 • 800-558-8690
sales@cainind.com
cainind.com

"Manufacturing Waste Heat Transfer Products to Save Energy"



Monthly: Payback vs. Fuel Savings

(Ref: 60938 Rev: 0 3/13/2018)

FOR

XYZ Company

'Red' indicates total monthly payback options for your specific application, paid by the monthly fuel savings.

'Blue' indicates your monthly anticipated fuel savings over 20 years (*240 months) of the equipment.

“\$29,554 MONTHLY FUEL SAVINGS”

1. Outright Purchase

Payback = \$201,007

Retained Fuel Savings = \$6,892,013

1	2	3	4	5	6	7	8	9	10	11	12	13	14	15	16	17	18	19	20	21	22	23	24
25	26	27	28	29	30	31	32	33	34	35	36	37	38	39	40	41	42	43	44	45	46	47	48
49	50	51	52	53	54	55	56	57	58	59	60	61	62	63	64	65	66	67	68	69	70	71	72
73	74	75	76	77	78	79	80	81	82	83	84	85	86	87	88	89	90	91	92	93	94	95	96
97	98	99	100	101	102	103	104	105	106	107	108	109	110	111	112	113	114	115	116	117	118	119	120
121	122	123	124	125	126	127	128	129	130	131	132	133	134	135	136	137	138	139	140	141	142	143	144
145	146	147	148	149	150	151	152	153	154	155	156	157	158	159	160	161	162	163	164	165	166	167	168
169	170	171	172	173	174	175	176	177	178	179	180	181	182	183	184	185	186	187	188	189	190	191	192
193	194	195	196	197	198	199	200	201	202	203	204	205	206	207	208	209	210	211	212	213	214	215	216
217	218	219	220	221	222	223	224	225	226	227	228	229	230	231	232	233	234	235	236	237	238	239	240

2. Equipment Lease vs. Fuel Savings (\$8,844 lease payment funded by monthly fuel savings)

Payback = \$212,250

Retained Fuel Savings = \$6,880,770

1	2	3	4	5	6	7	8	9	10	11	12	13	14	15	16	17	18	19	20	21	22	23	24
25	26	27	28	29	30	31	32	33	34	35	36	37	38	39	40	41	42	43	44	45	46	47	48
49	50	51	52	53	54	55	56	57	58	59	60	61	62	63	64	65	66	67	68	69	70	71	72
73	74	75	76	77	78	79	80	81	82	83	84	85	86	87	88	89	90	91	92	93	94	95	96
97	98	99	100	101	102	103	104	105	106	107	108	109	110	111	112	113	114	115	116	117	118	119	120
121	122	123	124	125	126	127	128	129	130	131	132	133	134	135	136	137	138	139	140	141	142	143	144
145	146	147	148	149	150	151	152	153	154	155	156	157	158	159	160	161	162	163	164	165	166	167	168
169	170	171	172	173	174	175	176	177	178	179	180	181	182	183	184	185	186	187	188	189	190	191	192
193	194	195	196	197	198	199	200	201	202	203	204	205	206	207	208	209	210	211	212	213	214	215	216
217	218	219	220	221	222	223	224	225	226	227	228	229	230	231	232	233	234	235	236	237	238	239	240

*Each cell represents one month of operation over the equipment life (240 months = 20 years) when operating on Natural Gas with proper water treatment and annual maintenance review.

"Manufacturing Waste Heat Transfer Products To Save Energy"

Boiler Economizer Systems · Gas & Diesel Cogeneration Systems · Fume Incineration Systems
Exhaust Steam Generators · Finned Tubing



CG260-16 Engine Heat Recovery Steam Generator
Re-Circulation Design with Exhaust Gas Bypass

Ref: 60938
Rep: 24290201
Rev: 0

Date: 3/13/2018

Engineered For:

ABC Company
P.O. Box 333
Mayville, WI 55555

Attn: Joe Foster
Ph: (555) 555-5555
Fax: (555) 555-1234

End User:

XYZ Company
PO Box 300
3333 W. Deer Blvd
Bloomville, WI 33333

Attn: Dave Calley
Ph: (333) 333-3333
Fax: (333) 333-1234

'Equipment Lease' option:

Cain Industries is also pleased to include a capital finance lease package option for review if budget constraints pose delay to begin your fuel savings.

- Included is the Equipment Lease, Credit Application and your Monthly Payback vs. Fuel Savings analysis, specific for your application.
- It's important to note that if you decide to take advantage of the convenience of a lease, your Monthly Fuel Savings will exceed and essentially fund the lease payments.
- As well the added amount of interest within the lease payments will only note a comparatively negligible cost to pay for the total equipment purchase.
- When the lease ends your company will own the equipment and enjoy monthly savings for years to come!

Upon acceptance, your Cain Representative will email to you an electronic version of your 'Savings Analysis Study' which includes both the Lease Quote and Credit Application. Simply contact the Leasing company listed on the Lease Quote. Typical approval process is fast and easy, taking only a few days.

“Manufacturing Waste Heat Transfer Products To Save Energy”

Boiler Economizer Systems • Gas & Diesel Cogeneration Systems • Fume Incineration Systems
Exhaust Steam Generators • Finned Tubing



LEASE QUOTE

Date:

To:	From:
Company:	Company:
Fax:	Fax:
Phone:	Phone:
Email:	Email:

Cain Industries is pleased to present the following lease quote for your consideration.

Lessee:

Equipment Description to Lease:

Total Equipment Cost:

Lease Financed Amount:

Interest Rate:

Lease Payment Amount:

Lease Term:

Fuel Savings:

Equipment Fuel Saving Payback:

Equipment Return on Investment:

Life Expectancy Fuel Savings:

Thank you for the opportunity to present the lease option and to be of service to you. This Lease Quote has been structured as an example to show your “monthly fuel savings” as it would pay the “monthly lease payment.” Your anticipated monthly fuel savings is based on your combustion source data and operation as submitted. Cain Industries guarantees that the proposed equipment to be leased will perform as noted in Cain’s Warranty. Upon contacting the lease company you can exercise the option to modify the Lease Payment Amount and Lease Term. Final rates are subject to credit review and term structure. This quote excludes any state and local sales tax and/or minor fees which may apply. My contact information is provided above should you have any questions or if additional information is required.

To proceed with the lease please contact:



American Capital

In Partnership with BMO Harris Bank N.A

Chris Ratay
Account Executive
630-512-0075 • Fax 630-512-0070
cratay@amcapfinance.com



American Capital Lease Application

In Partnership with BMO Harris Bank N.A



PLEASE TYPE OR PRINT ALL INFORMATION

Business Information

Credit Application

Company Legal Name / Lessee				DBA:	Phone:
Company Address:					Mobile:
City:	State:	County:	Zip:	Fax:	
Customer Contact:			Email Address:		Federal Tax ID #:
Contact Title:	Business Structure <input type="checkbox"/> Prop <input type="checkbox"/> Corp. <input type="checkbox"/> LLC <input type="checkbox"/> Part <input type="checkbox"/> Non-Profit			Age of Business:	Time Under Current Ownership
Equipment Usage Location:					Tax Exempt: Yes No

Bank References

Name of Bank / Branch:	Contact Person:	Phone #	Banker Email Address:
------------------------	-----------------	---------	-----------------------

Vendor and Equipment Information

Vendor Name:	Vendor Contact:	Vendor Phone:	Vendor Email Address:
Vendor Address	City:	State:	Zip:
Equipment to be Leased (attach Quote/Proposal)			Equipment Cost:
Lease Term <input type="checkbox"/> 24 mo <input type="checkbox"/> 30 mo <input type="checkbox"/> 36 mo <input type="checkbox"/> 42 mo <input type="checkbox"/> 48 mo <input type="checkbox"/> 54 mo <input type="checkbox"/> 60 mo		Purchase Option <input type="checkbox"/> 10% <input type="checkbox"/> \$1.00 <input type="checkbox"/> FMV	

Principal(s)/Guarantor(s) Information PLEASE TYPE OR PRINT ALL INFORMATION

PRINCIPAL'S NAME	TITLE	% OWNERSHIP	HOME PHONE NO	SOC SEC NO	DATE OF BIRTH
HOME ADDRESS (STREET)		(CITY)	(STATE)	(ZIP CODE)	
PRINCIPAL'S NAME	TITLE	% OWNERSHIP	HOME PHONE NO	SOC SEC NO	DATE OF BIRTH
HOME ADDRESS (STREET)		(CITY)	(STATE)	(ZIP CODE)	
PRINCIPAL'S NAME	TITLE	% OWNERSHIP	HOME PHONE NO	SOC SEC NO	DATE OF BIRTH
HOME ADDRESS (STREET)		(CITY)	(STATE)	(ZIP CODE)	

Authorization for Credit Inquiry

The undersigned (individually and collectively "Guarantor") whose signature(s) appear below personally and individually represent and warrant to American Capital Financial Services, Inc. ("ACFS") that Guarantor has an ownership interest in the Business identified in this application and that the information contained in this application is true and correct in all respects. Guarantor understands that Guarantor's personal guarantee(s) (with joint and several liability where there are multiple Guarantors) may be necessary to attempt to obtain funding for leasing equipment to the Business, and may be required if equipment is leased to the Business and Guarantor agrees to provide such guarantee(s) if so required. Guarantor authorizes ACFS, its agents, assigns and the financial institutions, funding sources, credit bureaus used by ACFS and any other person or entities working with ACFS to attempt to facilitate the leasing of equipment to the Business (all such individuals and entities hereinafter collectively referred to as "American Capital Affiliates") to investigate on an ongoing basis, obtain and share financial and related information from any source about Guarantor's personal credit standing and credit worthiness, including obtaining "consumer reports" as defined in the Fair Credit Reporting Act ("FCRA") for the purpose of evaluating Guarantor's personal credit worthiness to guarantee the Business's obligations under any actual or proposed equipment lease or extension or renewal thereof. By his or her signature, Guarantor, personally and individually, authorizes ACFS and their Affiliates to share Guarantor's personal consumer reports and other personal information and hereby directs any credit bureau or similar agency holding credit information, including "consumer reports" as defined in the FCRA, concerning Guarantor to provide such information to ACFS and their Affiliates for purposes indicated herein. Guarantor irrevocably waives any and all rights, claims and causes of action Guarantor might have under the FCRA against ACFS and its Affiliates for use of consumer reports or other materials for the purposes indicated herein. Guarantor represents and warrants that any equipment sought to be leased through ACFS will be exclusively for the Business's business use and not for personal, family or household purposes.

_____, Individually SIGNATURE PRINT NAME DATE

_____, Individually SIGNATURE PRINT NAME DATE

_____, Individually SIGNATURE PRINT NAME DATE



TERMS OF SALE

Bul. 25500

The terms of the attached Limited Warranty are included in these Terms of Sale and are incorporated by reference herein. The following "Terms of Sale" forms as a part of the Cain Industries equipment proposal as attached herein. All proposed pricing is quoted F.O.B. factory. All pricing is quoted in U.S. currency.

QUOTED DELIVERY TIME:

Delivery times quoted are appropriate for various product lines, and based on conditions at the time of quotation. Cain Industries, Inc. will, in good faith, attempt to deliver the equipment within the time quoted. In no case shall Cain Industries, Inc. be liable for incidental or consequential damages resulting from failure to meet requested or quoted delivery schedules. Quoted delivery time is based from the date of receipt of an approved written purchase order including written authorization to proceed with fabrication and the initial down payment if required, or from date of receipt of submittal drawings when required (less 10 working days).

OFFER EXPIRATION:

All offers expire 60 days from the quotation date unless otherwise stated and are subject to cancellation by Cain Industries, Inc. at any time prior to the formal acceptance of our offer to furnish equipment quoted.

SUBMITTAL DRAWINGS:

Submittal drawings are issued 5-10 working days from receipt of written purchase order, when required by either Cain Industries and/or the Buyer, and must be returned (marked "Approved for Production", signed, and dated) in order to initiate production. Production cannot begin until the approved submittal drawings are returned.

SHIPMENT OF GOODS:

Unless otherwise specifically agreed, all shipments are made F.O.B. Factory via "best way" and shipped freight collect. Cain Industries, Inc. responsibility ceases upon acceptance by the carrier. SHOULD GOODS BECOME LOST OR DAMAGED IN SHIPMENT, THE PURCHASER OR RECIPIENT OF THE GOODS MUST IMMEDIATELY NOTIFY AND PLACE CLAIM WITH THE CARRIER, ADVISE CAIN INDUSTRIES, INC. OF ANY DAMAGE OR DISCREPANCY, AND OBTAIN AUTHORIZATION FOR RETURN OR REPLACEMENT. As a courtesy, Cain Industries, Inc. will assist in tracing and recovering lost goods and the collection of just claims, but cannot guarantee safe delivery. Loss or damage in shipment does not release the purchaser from payment of the total invoice.

PAYMENT-ESTABLISHED ACCOUNTS:

Payments for established accounts with a credit limit are due on or before the Net 30 days from date of invoice due date, and coinciding with shipment date and/or 'ready for shipment date'.

EXPEDITING:

Expediting charges may be issued in order to improve delivery depending on the shorter delivery time required. Contact Cain Industries for pricing for the best possible delivery.

STORAGE:

When the equipment is ready for shipment, it will be shipped to the 'ship to' address noted on the Sales Order, unless otherwise indicated. Should there be a request to hold the equipment beyond the 'ready for shipment date', Cain will store the equipment for up to 30 days at no cost providing storage space is available. Contact Cain Industries for storage costs when equipment is expected to be stored for more than 30 days. If storage space is unavailable, the buyer agrees to make provisions to receive the equipment when it becomes ready for shipment.

MINIMUM BILLING:

The minimum order is \$100.00, plus shipping costs.

CREDIT LIMIT:

Accounts over credit limit will be on a "Cash with Order" basis until account is brought to below "Credit Limit" status. Special circumstances may occur where credit limits may be adjusted for companies with past credit history satisfactory to Cain Industries, Inc.

TAXES OR SURCHARGES:

Quoted prices do not include sales, use, excise, occupation, processing transportation or other similar taxes which Cain Industries, Inc. may be required to pay or collect with respect to any of the quoted materials. Such taxes which are or may be incurred shall be paid by the purchaser.

PAYMENT-NEW ACCOUNTS:

An initial purchase order received from a new account shall require a 50% down payment with the order, receipt of the completed credit application for immediate process-

ing, and the balance due prior to shipment; or 30% with purchase order and receipt of the completed credit application (order will be held until credit limit has been established) in conjunction with credit limit and/or progress payment schedules. Allow a 3 week processing period to complete the credit check.

PAYMENT-ORDERS OUTSIDE THE UNITED STATES:

For purchase orders received wherein the the final installation and/or the Buyer is located outside the United States, payments shall be made according to the guide lines as set forth herein. It is recommended that a Letter of Credit be created and issued with the purchase order for immediate order processing. All costs associated with international payments such as but not limited to: proforma invoicing, letter of credit, agents of record processing, currency adjustments, tariffs and special taxes, etc. shall be the responsibility of the purchaser. All payments shall be made in U.S. currency and shall be paid in full prior to shipment outside the United States.

SERVICE CHARGE:

A 2% per month service charge will be assessed on all past due amounts.

PROGRESS PAYMENT SCHEDULES:

The following are payment schedules for orders exceeding credit limit:

- For purchase orders of \$25,000 to \$50,000:
 - 30% due with purchase order
 - 30% due at 45 days from receipt of approval drawings
 - Balance due 30 days from shipment.
- Over \$50,000 or required for the ESG product orders:
 - 15% due with purchase order
 - 15% due with submittal approval drawings
 - 30% due 45 days from receipt of approved submittal drawings
 - 30% due prior to shipment
 - Balance due 30 days from shipment.

CANCELLATION AND CHANGES:

As many Cain Industries, Inc. products are manufactured and/or adjusted "to order", orders accepted and acknowledged by Cain Industries, Inc. are not subject to change or cancellation without prior consent of Cain Industries, Inc. Order quantity reductions or cancellations, if granted, will be subject to cancellation charges consistent with components "restockability versus made to order specifications" percent of production completion, etc.

EQUIPMENT STARTUP & SERVICE:

Pricing for equipment requiring startup or service: \$1100 per day for installations located within the continental United States; \$1300 per day for installations located in Canada; all other installation locations are quoted per application. Travel, lodging, and subsistence expenses are in addition. Startup can only be initiated upon receipt of completed Pre-Startup form. ESG & ESG1 boiler startups must be completed by authorized Cain personnel to allow the warranty to become effective, unless otherwise stated in a written agreement issued by Cain Industries to the Buyer.

RETURN OF GOODS FOR WARRANTY REPAIR, REPLACEMENT, OR CREDIT:

Authorization to return goods for any reason must be obtained from Cain Industries, Inc. prior to the return of the shipment being made. All items returned for repair, replacement or credit shall be returned freight prepaid. Freight collect shipments will not be accepted. A 30% "minimum" restocking charge will be made on all items returned for credit. Cancellation and/or restocking charges will apply to the balance of the order pending with a maximum of 90% as determined at the point of cancellation dependent on the work in process. Quantities shipped prior to the point of cancellation shall be issued an additional invoice for the difference in price breaks between the original quantity ordered and the total shipped up to the point of cancellation.

PROPRIETARY DATA:

All manufacturing drawings, specifications and technical material submitted by Cain Industries, Inc. are the property of Cain Industries, Inc. and are to be considered as confidential. Except for its original intent the submittal information supplied herein attached cannot be copied, transferred, or used in any way without the express written authorization from Cain Industries, Inc.

LIMITATION OF REMEDIES:

Cain's liability is limited exclusively to its obligations under the attached **Limited Warranty**, the terms of which are incorporated by reference herein. Buyer agrees that in no event will Cain be liable for cost of processing, loss of profits, or any other consequential or incidental damages or cost of any kind resulting from the order and or use of its product, whether arising from breach of warranty, non-conformity to order specifications, delay in delivery or any other loss sustained by buyer.



LIMITED WARRANTY AND PERFORMANCE GUARANTEE

Bul. 25500

LIMITED WARRANTY AND PERFORMANCE GUARANTEE

Cain Industries, Inc. warrants all products manufactured to be free from defects in material or workmanship under normal use and conditions for a period of one year from the date of startup or 18 months from date of shipment from our factory whichever occurs first. Cain Industries liability under this warranty to the buyer shall be limited to Cain's decision to repair or replace, all its factory items deemed defective after inspection at the factory or in the field. When field service is deemed necessary in order to determine a warranty claim, the costs associated with travel, lodging, etc. shall be the responsibility of the buyer except under prior agreement for a field inspection. All warranty claim requests must be initiated with a Material Return Authorization (MRA) number for processing and tracking purposes. The MRA number shall be issued to the buyer upon Cain's receipt of a purchase order for replacement component(s) required immediately and prior to warranty claim approval and/or a field inspection. No agent or employee of Cain Industries, Inc. has any authority to make verbal representation or warranty of any goods manufactured and sold by Cain Industries, Inc. without written authorization signed by an executive officer of Cain Industries, Inc. Cain Industries, Inc. warrants the equipment designed and fabricated to perform in accordance with the specifications as stated in the proposal for the equipment, and while the equipment is in new and clean condition and properly operated within the specific design limits for that equipment. Should any piece of equipment designed by Cain Industries, Inc. not meet performance requirements when determined by standard test procedures, Cain will make corrections it deems necessary at its option under the limitations of this warranty. Any alterations or repair of Cain equipment by personnel other than those directly employed by Cain shall void this warranty unless otherwise stated under a specific written guideline issued by Cain Industries to the buyer. The ESG1 and ESG boiler startup must be completed by authorized Cain personnel to allow the warranty to take effect unless otherwise stated in a written agreement issued by Cain Industries to the buyer. This warranty does not cover damage resulting from misapplying Cain Industries products and/or improper installation. This warranty does not cover corrosion resulting from the effects of physical or chemical properties of water, steam or the liquids or gases used in the equipment. This warranty does not cover damage resulting from combustion source backfires or explosions which exceed Cain Industries product specific maximum design pressure and/or when explosion hatches are not properly installed where required. This warranty does not cover damage resulting from excessive vibration resulting from isolating vibration protection not properly installed where required. This warranty does not cover damage resulting from expansion due to expansion joints not properly installed where required. This warranty does not cover damage or lost performance due to combustion source related deficiency such as soot build up on the heating surface. Cain makes no other warranties of performance or product either expressed or implied which extends beyond the limits contained within this instrument. All acceptance tests shall be conducted at the buyer's expense. Any such tests shall be made when the equipment is new, clean, and before being placed into service, and shall be made within 120 days of delivery. Where field test are required, the following procedures are to be used. The exhaust gas and liquid inlet and outlet temperatures shall be recorded simultaneously and measured at a minimum distance of 6 pipe diameters from the equipment. Exhaust gas and liquid volumes shall be determined by actual measurement, if practical, or by calculations if necessary. All factors of O₂, CO₂, excess air, full input, altitude and the operating efficiency of the primary direct fired unit, shall be incorporated in the final determination and calculation of the volume of the exhaust gas. The expense incurred for such test shall be the responsibility of the buyer and a copy of the test procedures conducted, data accumulated, and calculations used to arrive at the final results shall be submitted to Cain Industries. All workmanship, material and performance requirements shall be deemed to have been met if a contrary report has not been furnished within 120 days of delivery. This "Limited Warranty and Performance Guarantee" forms as a part of the Cain Industries equipment proposal as attached herein.

IN NO EVENT SHALL SELLER BE LIABLE FOR CLAIMS (BASED UPON BREACH OF EXPRESS OR IMPLIED WARRANTY, NEGLIGENCE OR OTHERWISE) FOR ANY DAMAGES, WHETHER DIRECT, IMMEDIATE, INCIDENTAL, FORESEEABLE, CONSEQUENTIAL, OR SPECIAL.



EXHAUST STEAM GENERATORS

Manufacturing Waste Heat Transfer Products To Save Energy

Boiler Economizer Systems · Gas and Diesel Cogeneration Systems · Fume Incineration Systems · Exhaust Steam Generators · Finned Tubing

GENERAL APPLICATION DATA - Request For Quote:

DATE: _____

Completed By: _____
Company: _____
Email Address*: _____

Initial Inquiry: *
 2019 pdf email inquiry phone misc inquiry email misc inquiry
 2019 tear form inquiry fax misc inquiry mail misc inquiry

Lead

Proposal To: * Fields with an asterisk are required

Company Name: _____
Address: _____
City, State/Province: _____ Postal Code: _____
Country: _____
Contact Name: _____
Email Address: _____
Phone: _____ Fax: _____

End User: Same As Proposal To

Company Name: _____
Address: _____
City, State/Province: _____ Postal Code*: _____
Country: _____
Contact Name: _____
Email Address: _____
Phone: _____ Fax: _____

1. Exhaust to Liquid Heating Source:

- Oven
- Furnace
- Thermal Oxidizer
- Other _____
- Fume Incinerator
- Natural Gas Engine
- Diesel Engine

Burner Type:

- Atmospheric
- Turbocharged
- Power Burner
- Naturally Aspirated

2. Exhaust Source Description: * New or Retrofit

Make: _____
Model: _____
BTU/Hr. input: _____ Number of Units: _____

For Engine Exhaust Retrofit:

kW@ (engines): _____
In.³ (engines): _____
RPM (engines): _____

3. Design Specifications:

Design Pressure: _____ PSIG
Operating Pressure: _____ PSIG

4. Exhaust Stack Description:

- Vertical gas flow direction
- Horizontal gas flow direction
- Stack Type:**
- Rectangular Dimensions: _____ X _____
- Cylindrical Diameter: _____

Economizer Space Limitations:

None or: _____

5. Type Of Fuel Burned:

- | | |
|---|---|
| Primary | Standby (for dual fuel burners) |
| <input type="radio"/> Natural Gas | <input type="radio"/> Natural Gas |
| <input type="radio"/> Propane | <input type="radio"/> Propane |
| <input type="radio"/> #2 Fuel Oil | <input type="radio"/> #2 Fuel Oil |
| <input type="radio"/> #4, 5, 6 Fuel Oil | <input type="radio"/> #4, 5, 6 Fuel Oil |
| <input type="radio"/> Landfill Gas | <input type="radio"/> Landfill Gas |
| <input type="radio"/> Biogas/Digester Gas | <input type="radio"/> Biogas/Digester Gas |
| Btu / Ft3 _____ | Btu/Gallon _____ |

6. Exhaust Gas Flow Entering: (Maximum pressure drop @ 100% load: _____ inches W.C.)

Temperature (°F):	_____	_____	_____	_____
<input type="radio"/> SCFM, or <input type="radio"/> ACFM, or <input type="radio"/> #/hr:	_____	_____	_____	_____
Desired Outlet (°F):	_____	_____	_____	_____
Content O2%:	_____	_____	_____	_____
or Content CO2%:	_____	_____	_____	_____
Content Excess Air%:	_____	_____	_____	_____
Thermal Efficiency %:	_____	_____	_____	_____
Load % of Input:	_____	_____	_____	_____
Hours of Operation per Load:	_____	_____	_____	_____
	Load 1	Load 2	Load 3	Load 4

7. Liquid Flow Entering: (Maximum pressure drop @ 100% load: _____ PSIG)

Temperature (°F):	_____	_____	_____	_____
<input type="radio"/> GPM, or <input type="radio"/> #/hr:	_____	_____	_____	_____
Desired Outlet (°F):	_____	_____	_____	_____

8. Desired BTU / Hr. Recovery: _____ BTU/Hr

9. Savings Analysis Information:

Fuel Cost Per 100,000 Btu: \$ _____
Total hours per year operation (loads 1 + 2 + 3 + 4): _____
Hours per day operation: _____
Days per week operation: _____
Weeks per year operation: _____

10. Justification for purchase:

Payback (months): _____ Return on Investment (%): _____

Attachments:

Please attach any files that you would like to submit with this request:

Notes:

Provide additional specifications or requirements (i.e. primary voltage, NEMA, etc.):

Attention:

Your combustion source description as listed above including operating conditions, fuel costs, etc. has either been instrument measured and/or noted by you. Because our quotation is a detailed analysis of expected savings for your specific application, please verify that the information is complete and accurate. This will allow us to proceed with compiling a comprehensive proposal for a Cain Industries, Inc. fuel-saving economizer system for your review.

Verified By*:

Cain Industries, Inc. · PO Box 189, Germantown, WI 53022 · 262.251.0051 · 800.558.8690 · Fax 262.251.0118 · sales@cainind.com